

6 1 5 1 4 3 1 2 1 1

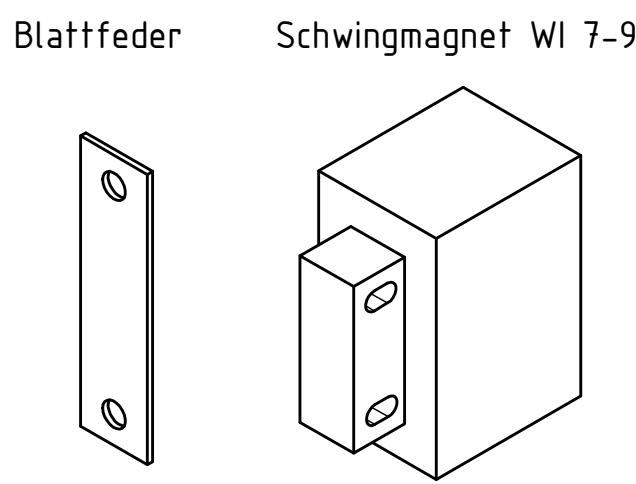

Stückliste		
OBJEKT	ANZAHL	BAUTEILNUMMER
1	4	530-220-1100-08 Magnetbaugruppe rechts
2	8	530-220-1100-11 Federbock kpl
3	1	530-220-1100-20-Winkel
4	1	530-224-1100-01-Unterteil
5	1	530-224-1100-02-Oberteil
6	1	530-224-1100-03 Pilz -VWF 32
7	1	530-224-1100-04-Bodenplatte
8	1	530-224-1100-05-Scheibe
9	1	530-224-1100-06-Transportstück
10	1	530-224-1100-16-Abdeckung
11	4	Elastikpuffer-40-40-M8
12	7	Skt. Mutter DIN 934 - M10
13	4	Stiftschraube DIN 835 - M10 x 65

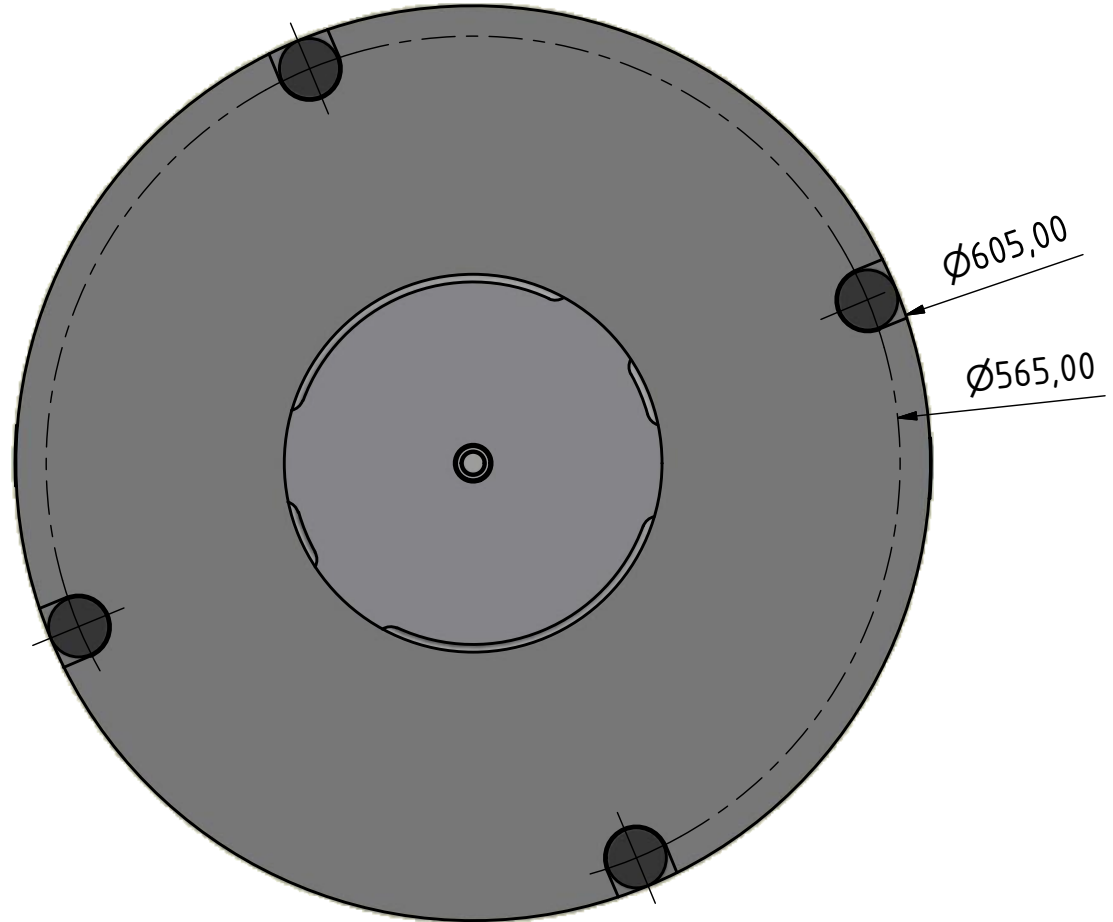
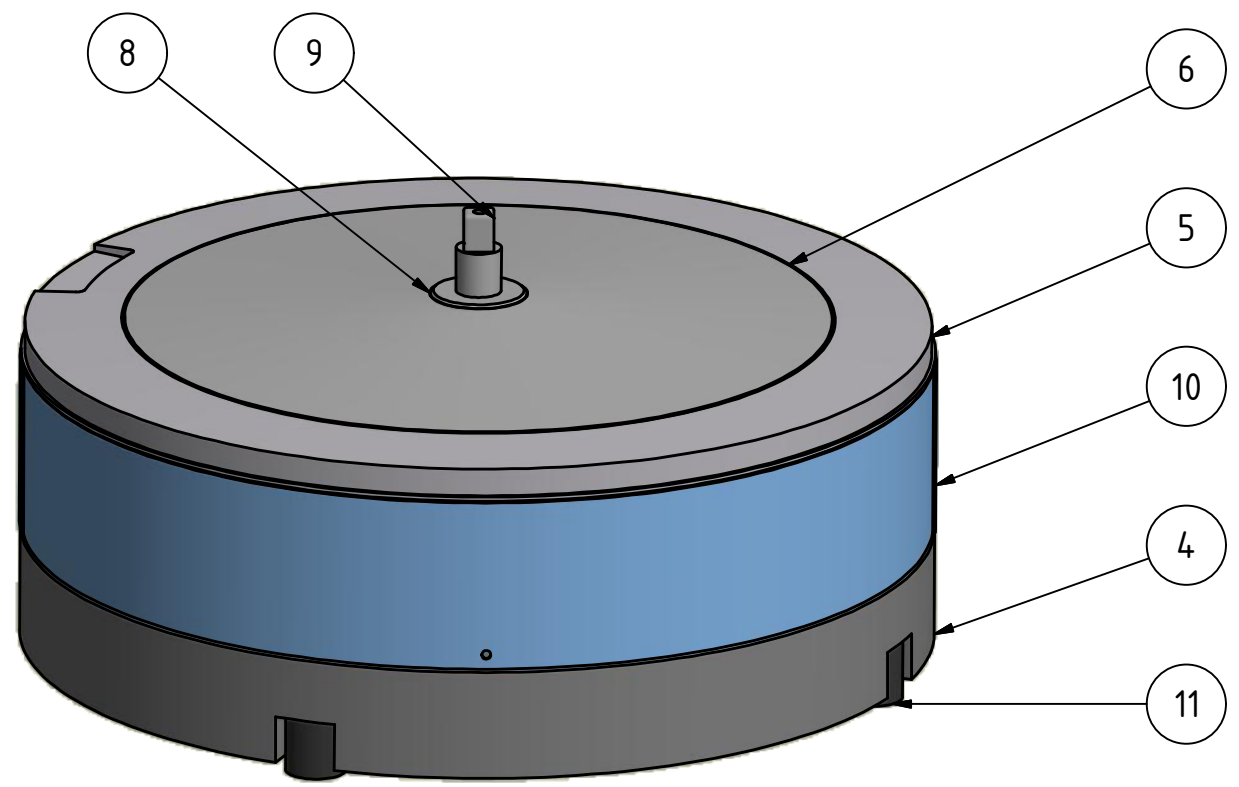
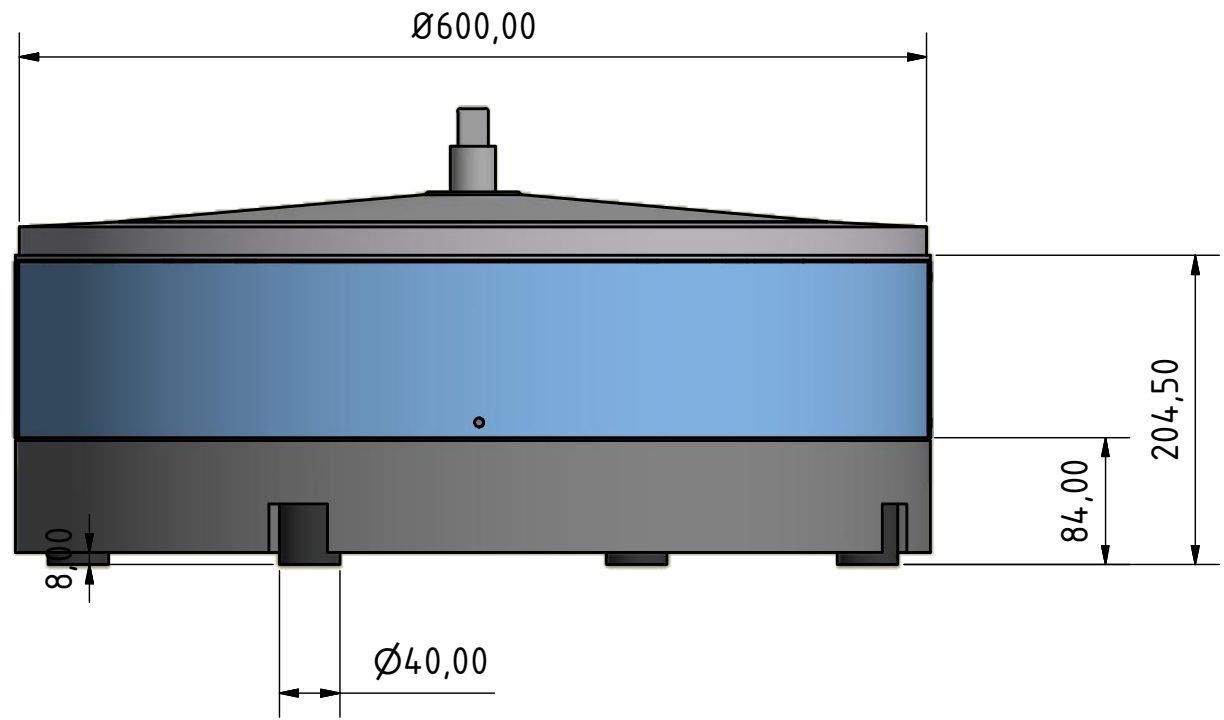

ads gmbh suhl							
		Datum		Name			
		Gezeichnet 09.07.2009		R.O.Adam			
		Kontrolliert					
		Norm					
						Grundgerät Vibrationsförderer	
						Gewicht: 207 Kg	
						Regler: Smart Nr.: 51221	
						530-224-1100-00-VWF-32-600	
						1	
						A3	
Status	Änderungen	Datum	Name				

6 1 5 1 4 3 1 2 1 1