

Blattfeder

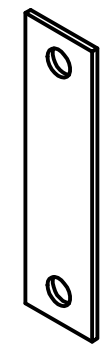

Schwingmagnet WI 7-9

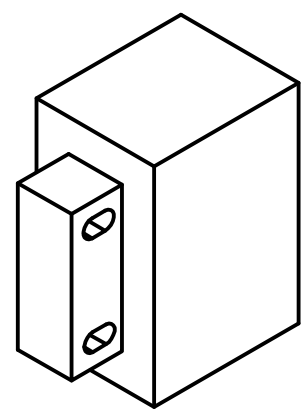

Stückliste		
Pos.	Menge	Benennung
1	1	530-220-1100-01-Unterteil-neu
2	1	530-220-1100-02-Oberteil
3	1	530-220-1100-03-Pilz
4	1	530-220-1100-04-Bodenplatte
5	1	530-220-1100-05-Scheibe
6	1	530-220-1100-06-Transportstück
7	3	530-220-1100-07 Magnetbaugruppe links
8	6	530-220-1100-11 Federbock kpl
9	1	530-220-1100-16-Abdeckung
10	1	530-220-1100-20-Winkel
11	1	530-220-1100-24 Staubschutz
12	3	Stiftschraube DIN 835 - M10 x 65
13	6	Skt. Mutter DIN 934 - M10
14	3	Elastikpuffer-40-40-M8

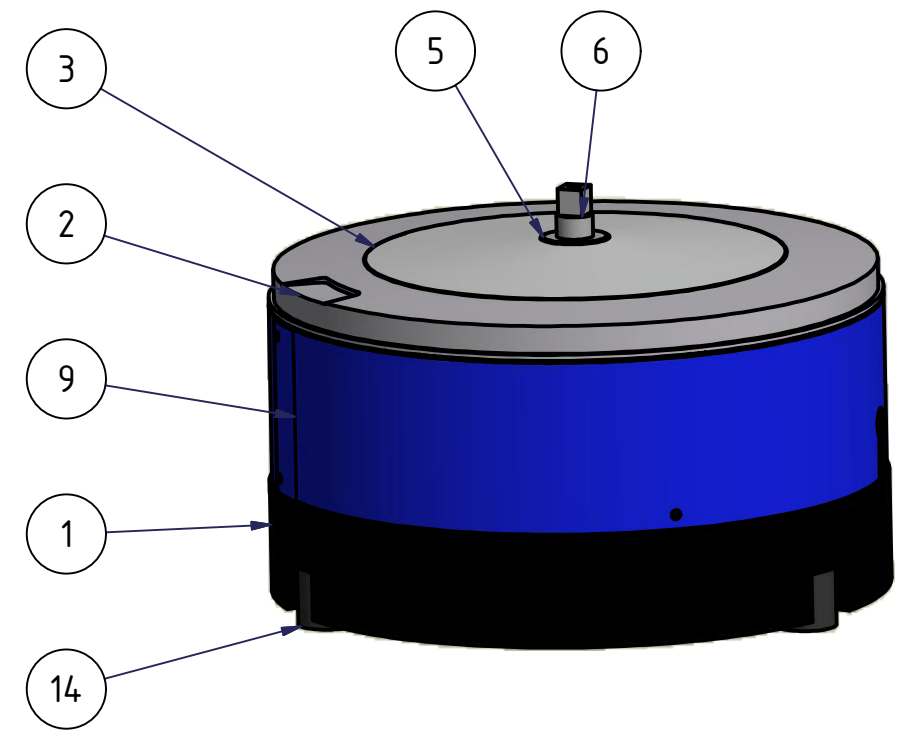
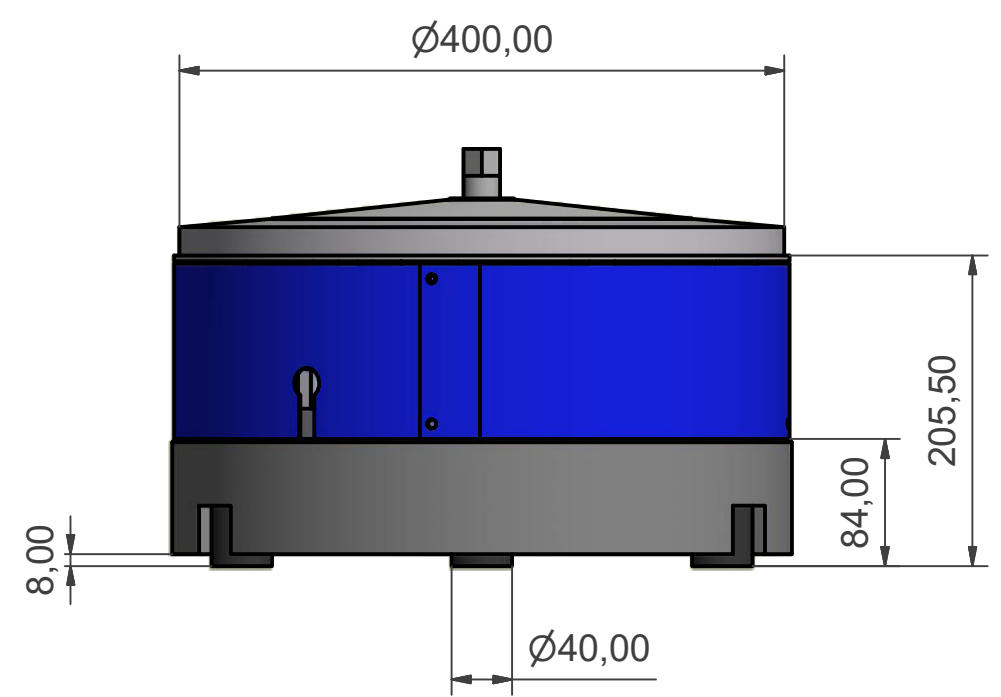

Allgemeintoleranzen DIN ISO 2768 fH		Oberflächen DIN ISO 1302		Werkstoff:		Maßstab: 1:5	
Datum		Name		Grundgerät Vibrationsförderer Gewicht: 90 kg Regler: SMART Nr.: 51221			
Gezeichnete 03.04.2013		L. Hartmann					
Kontrolliert							
Norm				530-220-1100-00-VWF16-400-Zsb.iam			
ADS SORTIERTECHNIK ENGINEERING						1	
www.ads-sortiertechnik.de						A3	